

# HOLLIS 2977C



<b>Bedrooms</b>	3/4
<b>Bathrooms</b>	2.5/3.5
<b>First Floor</b>	1364 sq. ft.
<b>Second Floor</b>	1613 sq. ft.
<b>Total Heated</b>	2977 sq. ft.

©2026. Saussy Burbank, LLC "Saussy Burbank" is a service mark of Saussy Burbank, LLC. Prices, plans, designs, architectural renderings, uses, dimensions, specifications, materials, availability, improvements and amenities depicted or described herein are subject to change or cancellation (in whole or in part) without notice. Illustrations may include artists' depictions and differ from final improvements. Equal housing opportunity.  
March 13, 2026

# HOLLIS 2977C

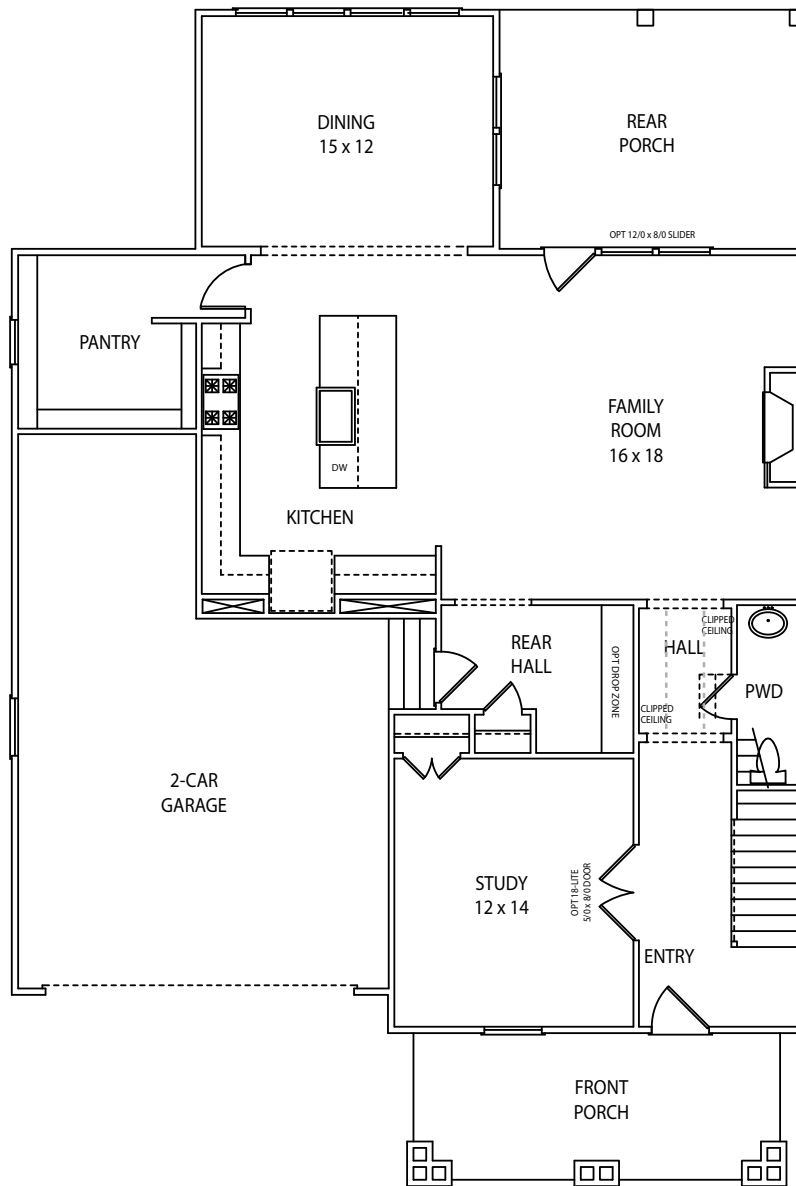
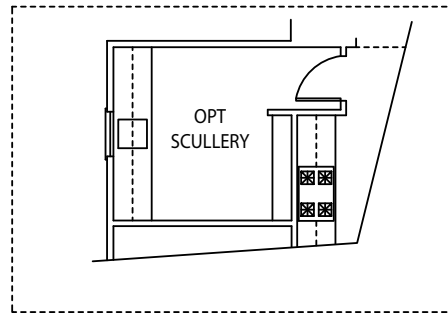

FIRST FLOOR  
STANDARD  
2977C

# HOLLIS 2977C

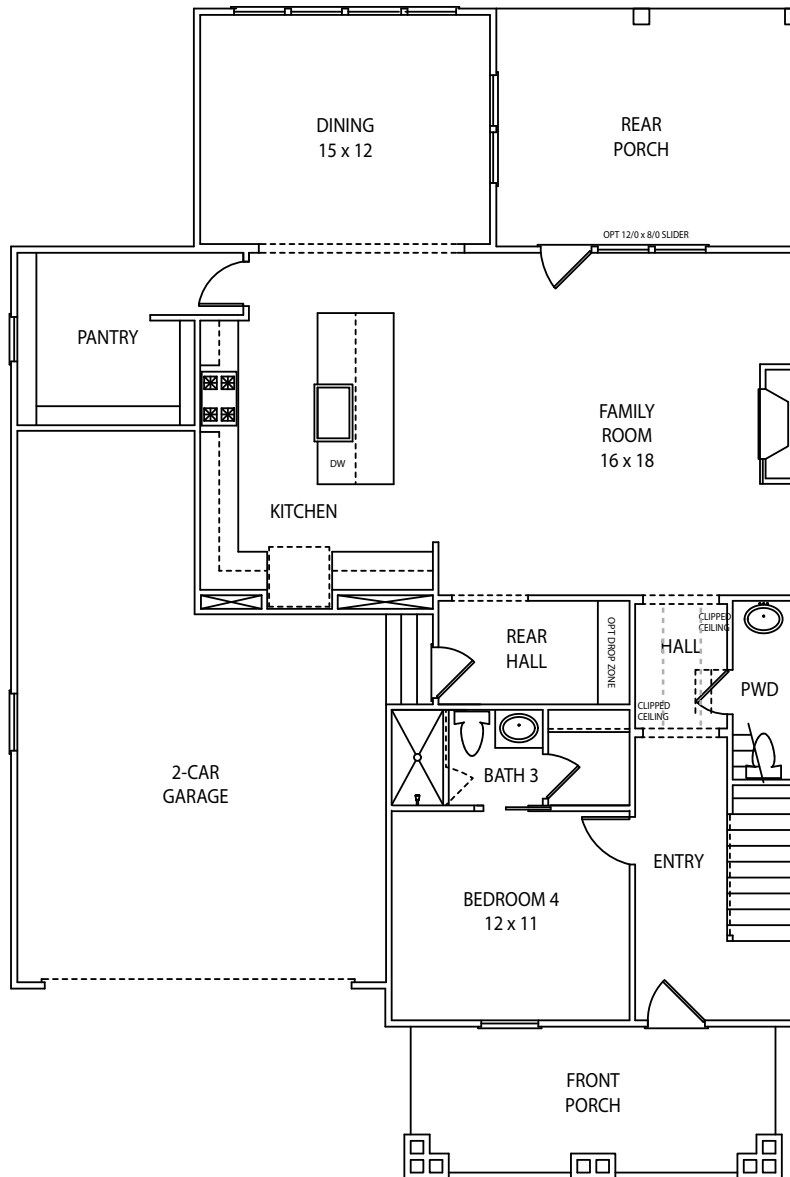
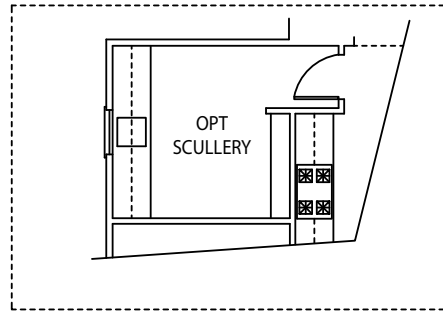

FIRST FLOOR  
OPT BEDROOM 4/BATH 3  
2977C

# HOLLIS 2977C

